

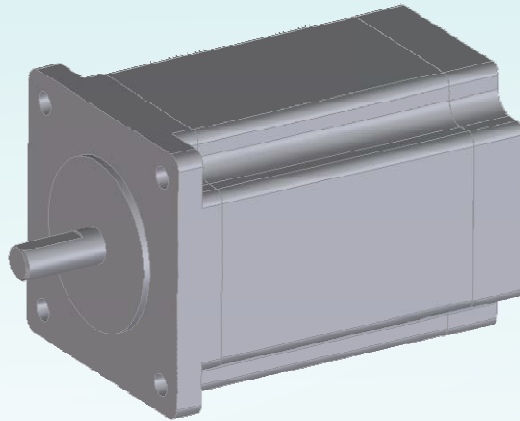

VFD Series

Installation manual



Bidirectional Power Supply

• High efficiency • Lightweight • Intelligent

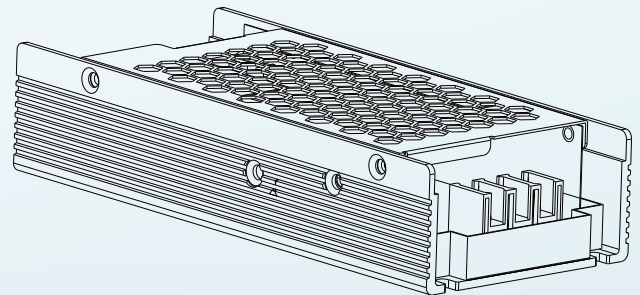
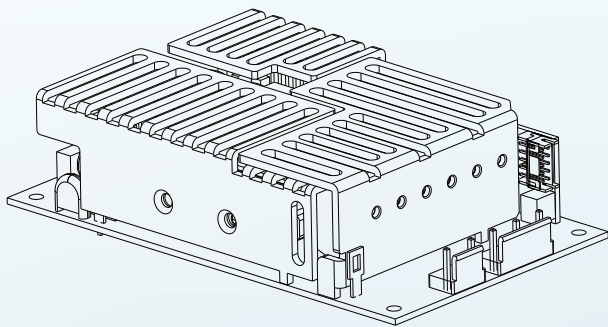

The VFD series is a three-phase motor drive module that can be used in combination with an external motor control circuit. The product family covers AC or DC input models and two mechanical design including chassis type and PCB type for different installation requirement. They are suitable for three-phase motors (BLDC, induction motors, synchronous reluctance motor) applications such as fans, water pumps, automatic doors, air conditioners, conveyor belts, and fitness equipment, etc.

Table of contents

1.Safety Precautions	1
2.Product Introduction	2
2.1 Model Encoding	2
2.2 Product Features	2
2.3 Electrical Specification Sheet	3
2.4 Derating Curves	6
2.5 Mechanical Drawings	9
3.Installation Instructions	11
3.1 Installation Precautions	11
3.2 Installation Steps	11
3.3 Configuration Examples	11
4.Interface Description	15
4.1 Connector Function Description	15
4.2 Control Pin Definition	16
5.Function Description	17
5.1 Three-phase, Six-switch IGBT Control Setting	17
5.2 Three-phase Current Detection and Over-current Protection	17
5.3 DC Bus Voltage Detection	18
5.4 IGBT Temperature Monitoring	19
5.5 Driver Error Alarm	20
6.Abnormal Conditions and Troubleshooting	21
7.Warranty	22
8.Environmental declaration information	23

1.Safety Precautions

- Turn off the power supply before installation or wiring.
- The output voltage is up to 220VAC , do not touch it during operation.
- The product can still hold an high voltage after turning off the power supply. Do not touch any parts on the product immediately to avoid danger. You can wait for 1 minute or take the initiative to unload the residual energy in the bulk capacitor before any further setting.
- The output AC terminal UVW cannot be connected to the AC power supply source.
- This product is used for three-phase motor loads and cannot be configured with single-phase motors or used for other purposes.
- Only qualified professional technician can install, wire, repair and perform maintenance to the driver.
- The product is non-isolated type. When connecting the functional connector, please note that the AC FG power supply for external signals should be removed or properly isolated to avoid damage.
- Do not put in or out the motor during operation to avoid overcurrent tripping or damage to the driver.

2.Product introduction

2.1 Model Encoding

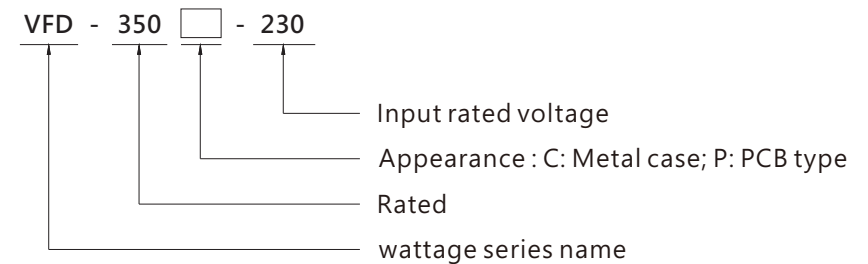

2.2 Product Features

- Multiple installation options: Chassis type / PCB type
- AC and DC input voltage options :
AC input type (built-in PFC function) : 90~264Vac
DC input type : 20~55Vdc
- Fanless design for no noise and long product life cycle
- Can be controlled with external controller
- High surge current 200% up to 5 seconds
- Equipped with basic protection functions: short circuit and overcurrent protection
- Provided multiple sensors for external control:
Current sensor: can be used in motor torque control DC bus
voltage sensor: can be used for over / under voltage protection
- Temperature sensor: can be used for over-temperature protection
- -30~+70 °C wide operating temperature range
- Suitable for three-phase motor load applications
(brushless DC motor / induction motor / synchronous reluctance motor ...)
- 3 years warranty

2.3 Electrical Specification Sheet

■ DC Input PCB Type (for 48V Motor)

MODEL NO.		VFD-150P-48	VFD-250P-48	VFD-350P-48
OUTPUT	VOLTAGE RANGE(UVW)	Three phase line-to-line 0~34V, suit for 48V class motor		
	CURRENT	4.3A	7.2A	10A
	RATED POWER	150W	250W	350W
	MAX. CURRENT	8.6A	14.4A	20A
	EFFICIENCY	93%	93%	92.5%
INPUT	RATED INPUT VOLTAGE	20 ~ 55VDC		
	RATED INPUT CURRENT	3.5A/48VDC Typ.	5.6A/48VDC Typ.	8.5A/48VDC Typ.
FUNCTION	INVERTER PWM INPUT	PWM control signal input for driving inverter IGBTs. (PIN8~13 of CN93) TTL input : IGBT ON: High(>2.6V); IGBT OFF: Low(<0.8V)		
	FAULT SIGNAL	Inverter fault signal(Short circuit/OCP, PIN7 of CN93). TTL input: Normal: High(>3V); Abnormal: Low(<0.5V)		
	DC BUS VOLTAGE SENSOR	DC BUS voltage sensor output(HV+ sensor, PIN1 of CN93): 2.5V@DC BUS 48V		
	THREE PHASE CURRENT SENSOR	Built-in 6mΩ low-side shunt resistor (each phase), (PIN4~6 of CN93)		
	THERMAL SENSOR	Built-in 10KΩ NTC for sensing IGBTs operating temperature. (TSM2A103F34D1R (Thinking Electronic), PIN2 of CN93)		
	AUXILIARY POWER VCC	Non-isolated 15V output power for user's application. Max current : 0.2A, Ripple:1V		
PROTECTION	SHORT CIRCUIT	Protection type : Shut down o/p voltage, re-power on to recover		
OUTPUT FREQUENCY	SWITCHING FREQUENCY RANGE	2.5KHz ~ 15KHz		
ENVIRONMENT	COOLING SYSTEM	Air convection		
	WORKING TEMP.	-30 ~ +70°C (Refer to "Dreating Curve")		
	WORKING HUMIDITY	20 ~ 90% RH non-condensing		
	STORAGE TEMP., HUMIDITY	-40 ~ +85°C, 10 ~ 95% RH non-condensing		
SAFETY & EMC	VIBRATION	10 ~ 500Hz, 2G 10min./1cycle, period for 60min. each along X, Y, Z axes		
	SAFETY STANDARDS	Design refer to EN61800-5		
	EMC EMISSION	Compliance to EN61800-3 C2		
OTHERS	EMC IMMUNITY	Compliance to BS EN/EN61000-4-2,3,4,5,6,8,11, EN61000-2-4, EN60146-1-1, EN61000-2-1		
	DIMENSION (L*W*H)	101.6*50.8*28.6mm		
OTHERS	PACKING	0.09kg	0.09kg	0.1kg

■ AC Input PCB Type (for 230V Motor)

MODEL NO.		VFD-250P-230		VFD-350P-230	
OUTPUT	VOLTAGE RANGE(UVW)	Three phase line-to-line 0~240V, suit for 200-240V class motor			
	CURRENT	CONNECTION	1A	1.4A	
		15CFM	1.6A	2.2A	
	POWER	CONNECTION	250W	350W	
		15CFM	400W	550W	
	PEAK CURRENT	2A		2.8A	
	EFFICIENCY	91.5%		93%	
	DC BUS VOLTAGE	380±5VDC			
INPUT	RATED INPUT VOLTAGE	90 ~ 264VAC			
	INPUT FREQUENCY RANGE (Hz)	47 ~ 63Hz			
	POWER FACTOR (Typ.)	PF>0.99/115VAC, PF>0.93/230VAC		PF>0.99/115VAC, PF>0.93/230VAC	
	RATED INPUT CURRENT	2.6A/115VAC	1.3A/230VAC	3.5A/115VAC	2A/230VAC
	INRUSH CURRENT	Cold start 70A			
FUNCTION	INVERTER PWM INPUT	PWM control signal input for driving inverter IGBTs. (PIN8~13 of CN93) TTL input : IGBT ON: High(>2.6V); IGBT OFF: Low(<0.8V)			
	FAULT SIGNAL	Inverter fault signal(Short circuit/OCP, PIN7 of CN93). TTL input: Normal: High(>3V); Abnormal: Low(<0.5V)			
	DC BUS VOLTAGE SENSOR	DC BUS voltage sensor output(HV+ sensor, PIN1 of CN93): 2.5V@DC BUS 380V			
	THREE PHASE CURRENT SENSOR	Built-in 100mΩ low-side shunt resistor (each phase), (PIN4~6 of CN93)			
	THERMAL SENSOR	Built-in 10KΩ NTC for sensing IGBTs operating temperature. (TSM2A103F34D1R (Thinking Electronic), PIN2 of CN93)			
AUXILIARY POWER VCC	Non-isolated 15V output power for user's application. Max current : 0.1A, Ripple:1V				
PROTECTION	SHORT CIRCUIT	Protection type : Shut down o/p voltage, re-power on to recover			
OUTPUT FREQUENCY	SWITCHING FREQUENCY RANGE	2.5KHz ~ 15KHz			
ENVIRONMENT	COOLING SYSTEM	Air convection			
	WORKING TEMP.	-30 ~ +70°C (Refer to "Dreating Curve")			
	WORKING HUMIDITY	20 ~ 90% RH non-condensing			
	STORAGE TEMP., HUMIDITY	-40 ~ +85°C, 10 ~ 95% RH non-condensing			
	VIBRATION	10 ~ 500Hz, 2G 10min./1cycle, period for 60min. each along X, Y, Z axes			
SAFETY & EMC	SAFETY STANDARDS	Design refer to EN61800-5			
	WITHSTAND VOLTAGE	I/P-FG:2KVAC			
	ISOLATION RESISTANCE	I/P-FG:100M Ohms/500VDC/25°C/70%RH			
	EMC EMISSION	Compliance to EN61800-3 C2, BS EN/EN61000-3-2,-3			
	EMC IMMUNITY	Compliance to BS EN/EN61000-4-2,3,4,5,6,8,11, EN61000-2-4, EN60146-1-1, EN61000-2-1			
OTHERS	DIMENSION (L*W*H)	127*76.2*35mm			
	PACKING	0.26kg		0.27kg	

■ AC Input Chassis Type (for 230V Motor)

MODEL NO.	VFD-200C-230	VFD-350C-230	VFD-750C-230	
OUTPUT	VOLTAGE RANGE (UVW)	Three phase line-to-line 0~240V, suit for 200-240V class motor		
	CURRENT	0.8A	1.4A	3A
	RATED POWER	200W	350W	750W
	MAX. CURRENT	1.6A	2.8A	6A
	EFFICIENCY	92%	93%	93%
	DC BUS VOLTAGE	380 ± 5VDC		
INPUT	RATED INPUT VOLTAGE	90 ~ 264VAC		
	INPUT FREQUENCY RANGE (Hz)	47 ~ 63Hz		
	POWER FACTOR (Typ.)	PF>0.99/115VAC, PF>0.93/230VAC	PF>0.99/115VAC, PF>0.93/230VAC	PF>0.99/115VAC, PF>0.93/230VAC
	RATED INPUT CURRENT	2.6A/115VAC 1.1A/230VAC	3.5A/115VAC 2A/230VAC	8A/115VAC 4A/230VAC
	INRUSH CURRENT	Cold start 50A		
FUNCTION	INVERTER PWM INPUT	PWM control signal input for driving inverter IGBTs. (PIN8~13 of CN93) TTL input: IGBT ON: High(>2.6V); IGBT OFF: Low(<0.8V)		
	FAULT SIGNAL	Inverter fault signal(Short circuit/OCP, PIN7 of CN93). TTL input: Normal: High(>3V); Abnormal: Low(<0.5V)		
	DC BUS VOLTAGE SENSOR	DC BUS voltage sensor output(HV+ sensor, PIN1 of CN93): 2.5V@DC BUS 380V		
	THREE PHASE CURRENT SENSOR	Built-in 100mΩ low-side shunt resistor (each phase), (PIN4~6 of CN93)		
	THERMAL SENSOR	Built-in 10KΩ NTC for sensing IGBTs operating temperature. (TSM2A103F34D1R (Thinking Electronic), PIN2 of CN93)		
	AUXILIARY POWER VCC	Non-isolated 15V output power for user's application. Max current : 0.1A, Ripple:1V		
PROTECTION	SHORT CIRCUIT	Protection type : Shut down o/p voltage, re-power on to recover		
OUTPUT FREQUENCY	SWITCHING FREQUENCY RANGE	2.5KHz ~ 15KHz		
ENVIRONMENT	COOLING SYSTEM	Air convection		
	WORKING TEMP.	-30 ~ +70°C (Refer to "Derating Curve")		
	WORKING HUMIDITY	20 ~ 90% RH non-condensing		
	STORAGE TEMP., HUMIDITY	-40 ~ +85°C, 10 ~ 95% RH non-condensing		
	VIBRATION	10 ~ 500Hz, 2G 10min./1cycle, period for 60min. each along X, Y, Z axes		
SAFETY & EMC	SAFETY STANDARDS	Design refer to EN61800-5		
	WITHSTAND VOLTAGE	I/P-FG:2KVAC		
	ISOLATION RESISTANCE	I/P-FG:100M Ohms/500VDC/25°C / 70%RH		
	EMC EMISSION	Compliance to EN61800-3 C2, BS EN/EN61000-3-2,-3		
	EMC IMMUNITY	Compliance to EN61800-3		
OTHERS	DIMENSION (L*W*H)	146*55*26mm	146*62*31mm	150*100*41mm
	PACKING	0.31kg	0.38kg	0.8kg

2.4 Derating Curves

■ Derating Curve vs Ambient Temperature (PCB Type)

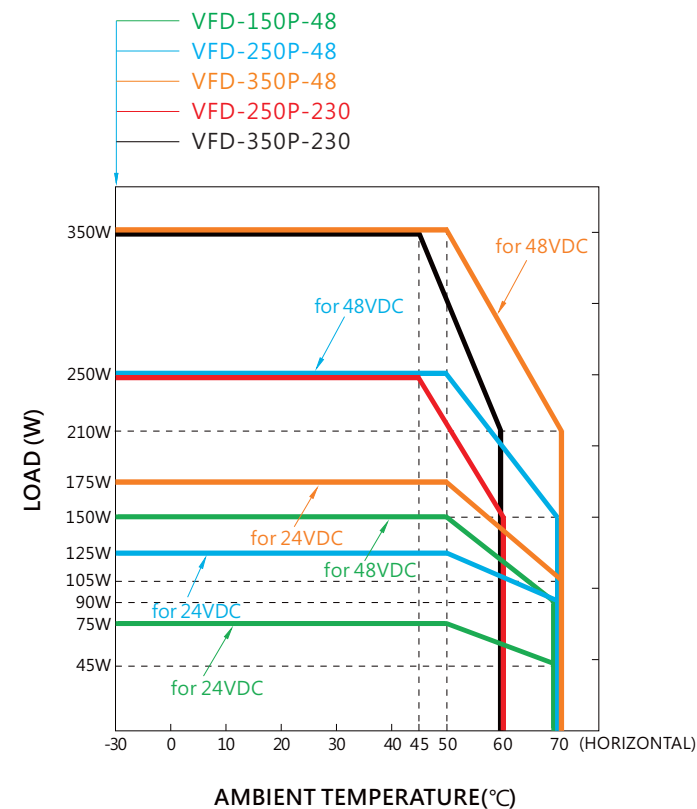

■ Derating Curve vs Ambient Temperature (Chassis Type)

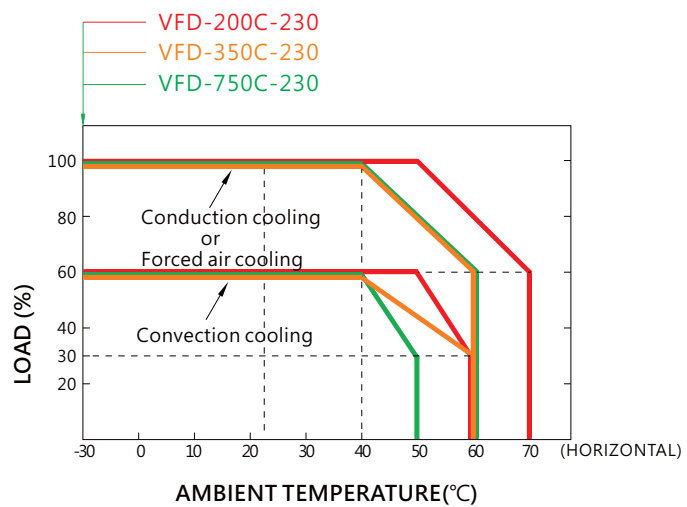

■ Output Derating vs Input Voltage

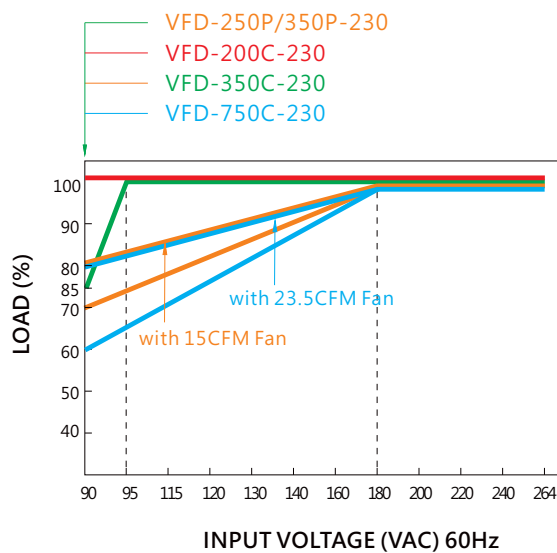
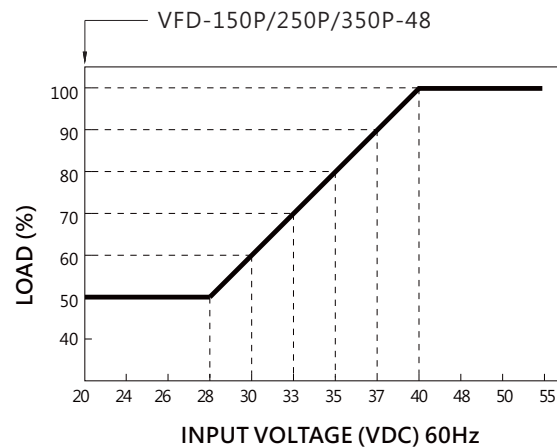

2.5 Mechanical Drawings

■ VFD-150P-48 /VFD-250P-48/VFD-350P-48

Unit :mm

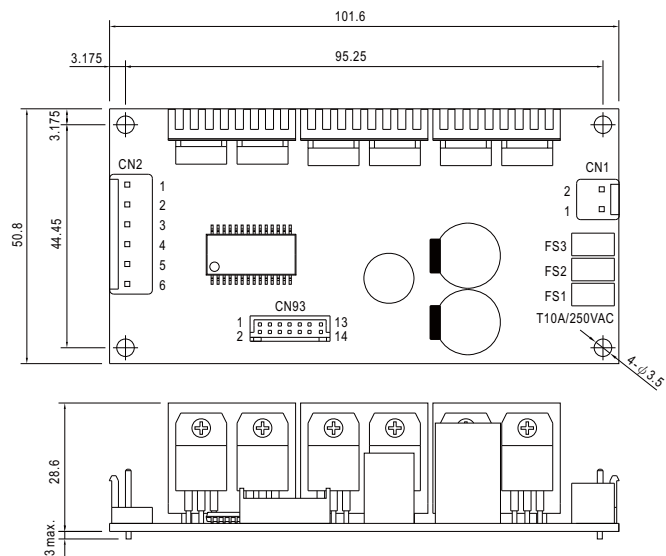

■ VFD-250P-230 /VFD-350P-230

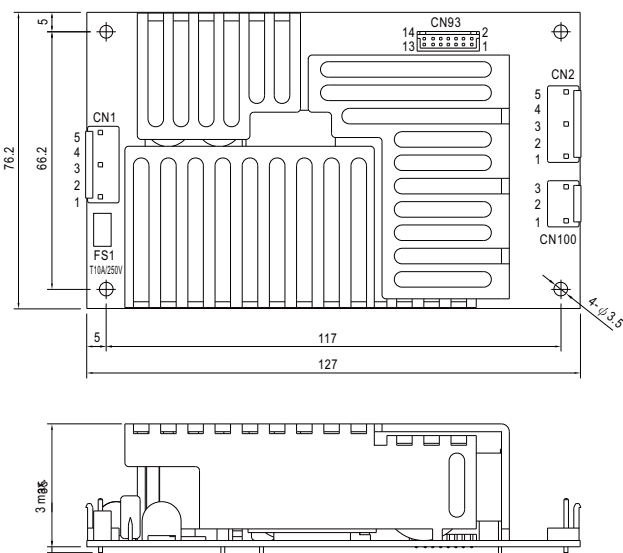

■ VFD-200C-230 /VFD-350C-230

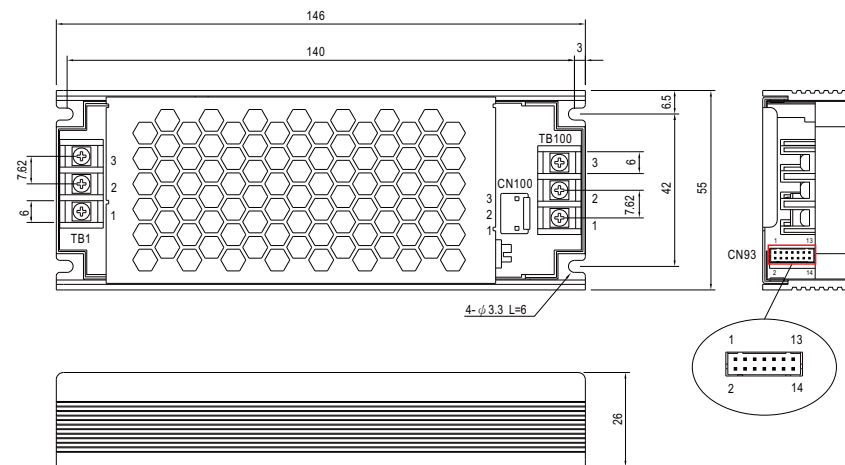

■ VFD-750C-230

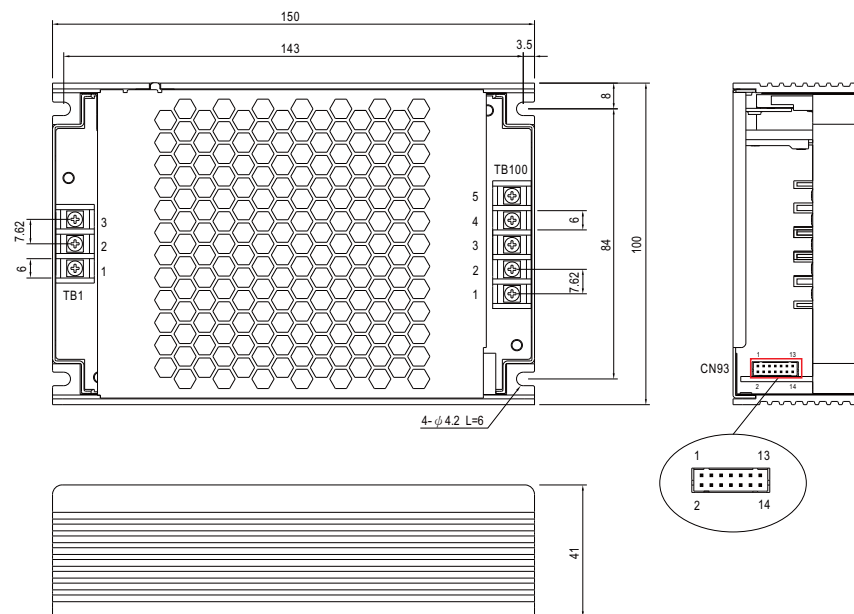

3. Installation Instructions

3.1 Installation Precautions

- Do not use the product in high temperature or high humidity environment to avoid failure or affecting the lifetime of the VFD driver product.
- VFD series products are with fan-less design. Pay attention to the derating curve for the installation environment and operating power to avoid driver entering protection mode or damaged.

3.2 Installation Steps

- Select appropriate wires to connect the VFD , power supply and motor load according to the rated current on specification.
- The terminals must be connected correctly. The wire connecting between the VFD and motor must follow correct sequence of the UVW phase to avoid steering errors or operational failures.

3.3 Configuration Examples

- VFD series system block diagram

AC input type : VFD-250P-230/ VFD-350P-230/ VFD-200C-230/
VFD-350C-230

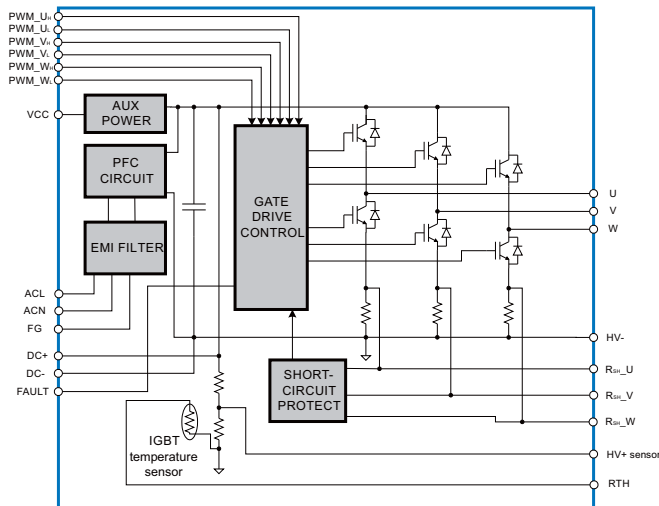

AC input type : VFD-750C-230

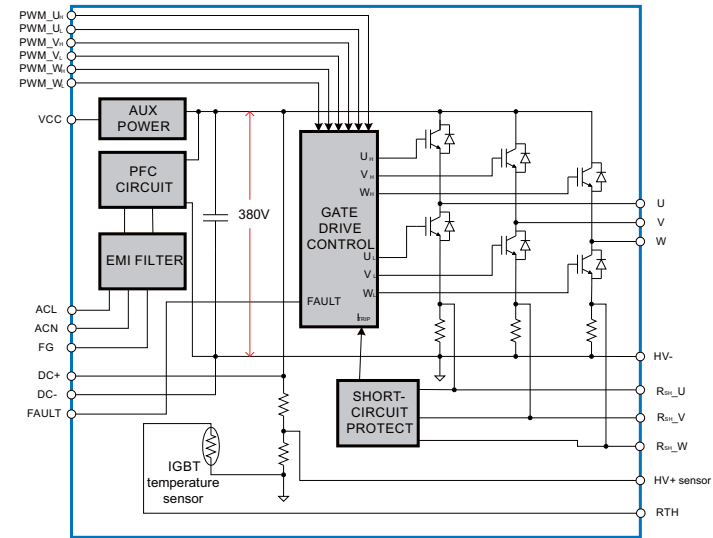

DC input type : VFD-150P-48/ VFD-250P-48/ VFD-350P-48

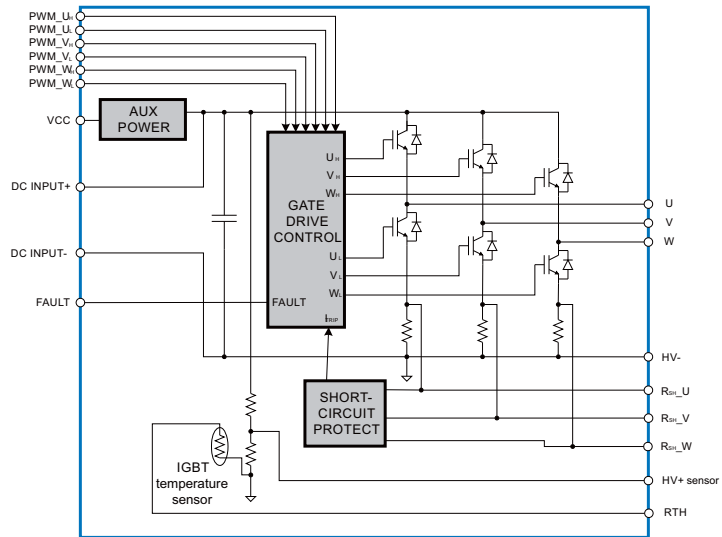

- Application configuration example (BLDC motor application)

- The figure below shows a typical configuration of VFD series products used in BLDC motor drives.
 - Developers can make own design on the external control boards and use them with the VFD series products to achieve motor control applications.
 - The external control board should generate 3 phase PWM signal to the the six-switch on the VFD series (PWM_UH/UL/VH/VL/WH/WL , PIN8~13).
- The VFD series provide three-phase current / DC bus voltage / temperature feedback signals, by means of OPA or voltage divider, for the external control board to detect the motor behavior and generate motor control signal.
- In certain cases, there are position sensors (Hall-effect sensor or Encoder ...) in the motor to feedback motor status for controlling. If you need a control card with sensor input ports, please contact MEAN WELL for optional control boards.
 - In order to avoid damage to the driver, over-voltage protection should be provided by the system to avoid damage to the VFD product. The maximum DC bus voltage is 420V for the AC input models or 60V for the DC input models.
 - If there is a need for a regenerative braking circuit, connect the regenerative braking circuit to the DC + and DC - pins to avoid overvoltage on the driver's DC bus due to motor regenerative power.

AC input type : VFD-250P-230/ VFD-350P-230/ VFD-200C-230/
VFD-350C-230/ VFD-750C-230

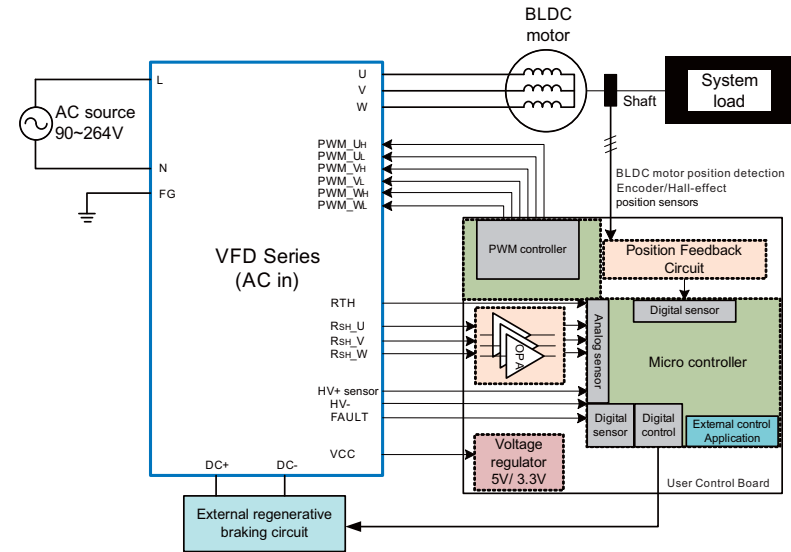

DC input type : VFD-150P-48/ VFD-250P-48/ VFD-350P-48

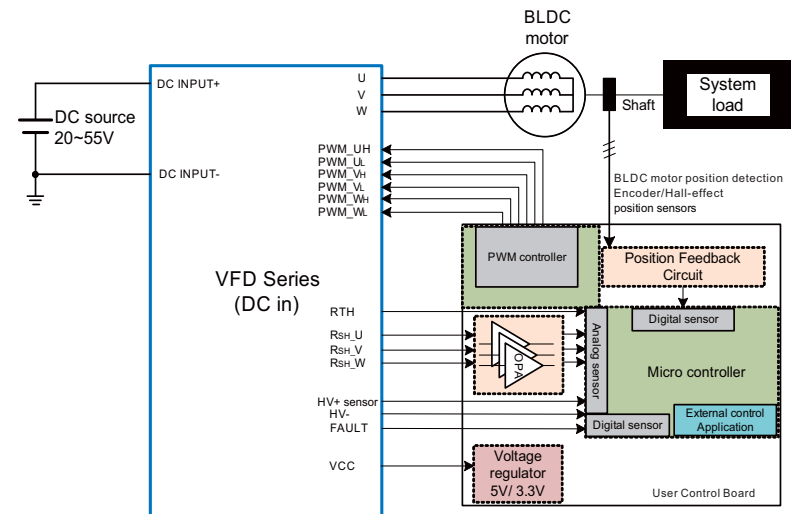

4.Interface Description

4.1 Connector Function Description

- Ⓐ **Input connection terminals:**
Connect the appropriate power supply according to the input specification (230V or 48V models) .
- Ⓑ **Three-phase output connection terminals:**
Three-phase voltage output terminal, typically connected to three-phase motors .
- Ⓒ **DC bus output connection terminals (230 type only):**
The DC bus voltage output is used to connect the external regenerative brake circuit. If required, the 48 type can be configured directly at the input connection terminals .
- Ⓓ **CN93 control pin terminals:**
Functional/Control pins to be connected to the external control boards, please refer to Section 5 for more detail .

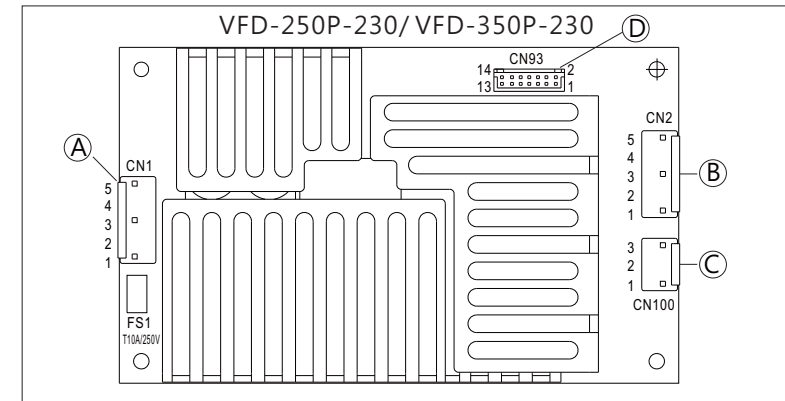
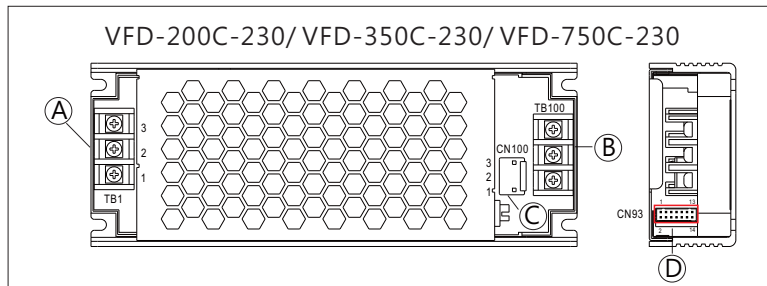
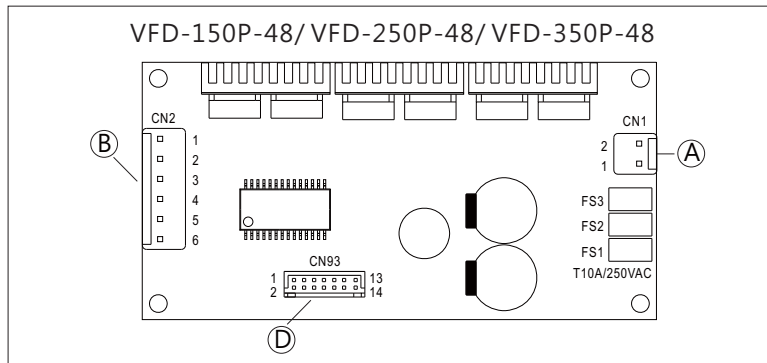

4.2 Control Pin Definition

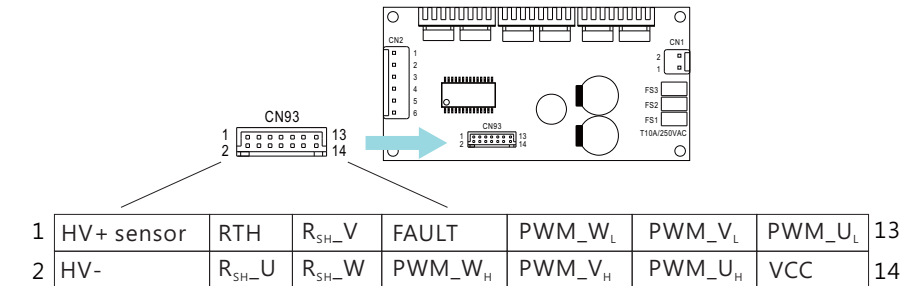

Pin No	Function	Description
1	HV+ sensor	DC BUS voltage sensor output 2.5V, reference to pin 2(HV-)
2	HV-	DC BUS voltage sensor output ground
3	RTH	Temperature sensor output
4	R _{SH_U}	U phase current sensor output
5	R _{SH_V}	V phase current sensor output
6	R _{SH_W}	W phase current sensor output
7	FAULT	Overcurrent detection. Normal > 3V ; Abnormal < 0.5V
8	PWM_W _H	W phase high side logic input, on > 2.6V : OFF < 0.8V
9	PWM_W _L	W phase low side logic input, on > 2.6V : OFF < 0.8V
10	PWM_V _H	V phase high side logic input, on > 2.6V : OFF < 0.8V
11	PWM_V _L	V phase low side logic input, on > 2.6V : OFF < 0.8V
12	PWM_U _H	U phase high side logic input, on > 2.6V : OFF < 0.8V
13	PWM_U _L	U phase low side logic input, on > 2.6V : OFF < 0.8V
14	VCC	Auxiliary voltage output 14.5~15.5V reference to pin(HV-). The maximum load current is 0.1A

5.Function Description

5.1 Three-phase, Six-switch IGBT Control Setting

The VFD series products have internally 3 sets of half-bridge IGBT in parallel which forms three-phase, six-switch circuits. The 6 IGBTs are controlled by input signals PWM_UH/PWM_UL/PWM_VH/PWM_VL/PWM_WH/PWM_WL respectively (PIN8~13) . Input signal electrical level is compatible with TTL and CMOS 3.3V controller signals. Recommended wiring is as follows.

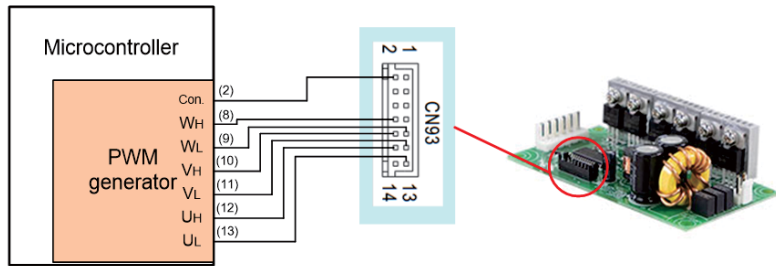

Note that simultaneous activation on the high-side (H) and the low-side (L) switches on the same phase is prohibited. A switching control signals dead-time ($t_{dead}(Min.)$) of 300ns or above is required.

5.2 Three-phase Current Detection and Over-current Protection

The VFD series products have three built-in current shunt resistors placed to the three phase low-side circuit loop respectively. This signal can be used for internal over-current protection of the VFD product and provided to external controller for current detection. The recommended connection for this signal is as short as possible and better to OPA for the readout circuit to obtain the best detection results.

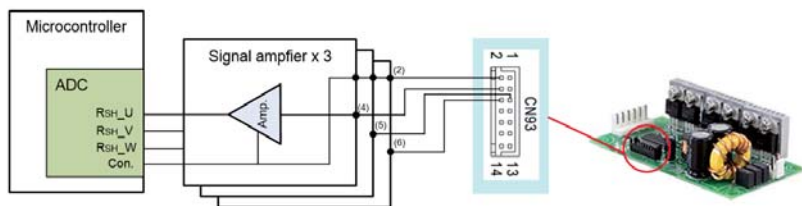

When the output is in overcurrent state due to abnormal condition such as short circuit, the VFD's built-in overcurrent detection circuit will trigger ITRIP signal and turn off the Gate driver to protect the VFD product hardware. ITRIP signal is triggered when output current is higher than 200% rated current.

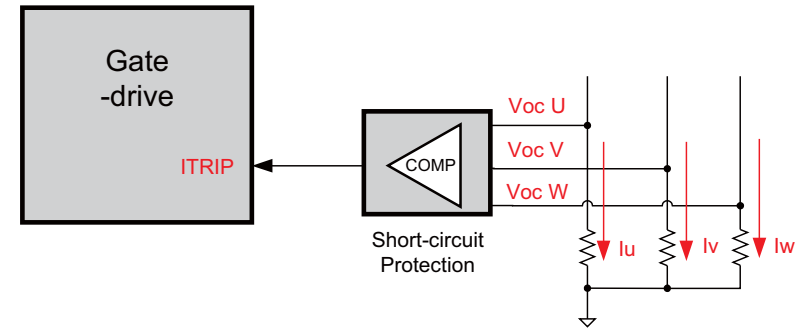

5.3 DC Bus Voltage Detection

The VFD products have built-in DC bus voltage detection signal - HV+ sensor . This signal level is correspond to the DC bus voltage level. When DC bus is at 380V (for AC models) or 48V (for DC models) the HV+ sensor will be at 2.5V. Similar to the current detection circuit suggestions, it is recommended to use an OPA circuit for the readout for the HV+ sensor signal. To avoid product damage, when the detected voltage is higher than 420V (for AC models) or 60V (for DC models), it is recommended to turn off the PWM switch and/or design a regenerative braking resistor to absorb the regenerative power.

(交流版)

$$V_{DC\text{ BUS}} = \frac{380 \times \text{HV+ sensor}}{2.5}$$

(直流版)

$$V_{DC\text{ BUS}} = \frac{48 \times \text{HV+ sensor}}{2.5}$$

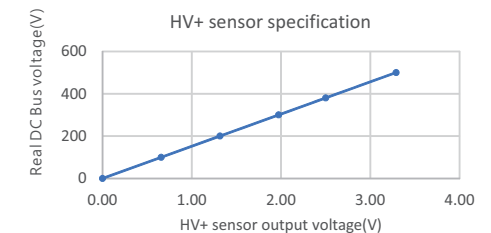

5.4 IGBT Temperature Monitoring

The VFD product has built-in NTC resistor or temperature sensor for detecting the temperature of the IGBT component. This signal can be used for the users to design the control or protection functions for the IGBTs. The recommended circuits are as follows :

- VFD-150P-48/VFD-250P-48/VFD-350P-48/VFD-250P-230/
VFD-350P-230/VFD-200C-230/VFD-350C-230:

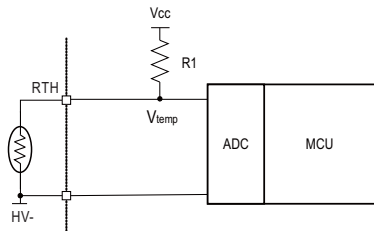

Recommended protection temperature : please refer to each specification sheet

- VFD-750C-230:

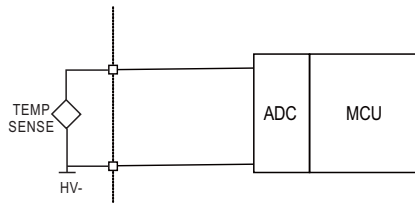

Recommended protection temperature : 3V

Recommended NTC TSM2A103F34D1RZ specification sheet :

Part No.	Zero Power Resistance at 25°C	Tolerance of R ₂₅	B _{25/85} Value	Tolerance of B Value	Max. Power Dissipation at 25°C	Dissipation Factor	Thermal Time Constant	Operating Temperature Range
	R ₂₅ (KΩ)	(± %)	(K)	(± %)	P _{max} (mW)	δ (mW/°C)	τ (sec.)	T _L ~T _U (°C)
TSM2A103F34D1RZ	10	1	3435	1	240	Approx. 2.4	Approx. 5.4	-40 ~ +125

5.5 Driver Error Alarm

When an overcurrent condition occurs in the VFD product, the FAULT signal will be enabled (active-low) . When the overcurrent duration longer than $T_{\text{Tripmin.}}$, FAULT signal will trigger an action and notify the external control circuit that an error occurs in the VFD driver.

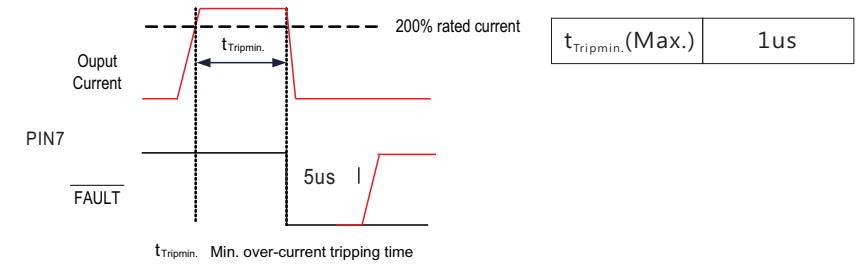

6. Abnormal Conditions and Troubleshooting

Phenomenon	Possible Causes	Solutions
No output	Wrong input power connection	Confirm whether the input wiring is correct
	PFC circuit damaged	Confirm whether the DC Bus capacitor voltage reaches $380V \pm 10V$
	External control board does not give correct signals to the PWM control circuit.	Is the connection between the main board of the VFD product and the small board of external control circuit correct?
DC bus overvoltage	Motor regenerative power generation	Confirm whether the matching motor is used in deceleration regeneration mode. If so appropriate regenerative discharge control circuit should be added to suppress the voltage peaks on DC bus due to regenerative power.
Wrong steering with motor	UVW is not configured according to VFD three-phase output connector definition	Confirm the correctness of wiring and the correctness of customer control board design including Uvw sequence definition.

If the fault still cannot be eliminated, please contact MEAN WELL or a MEAN WELL dealer for further support.

7. Warranty

If the products are used under limits and according to the specifications, one can enjoy 5 years warranty with free repair service. Please do not replace parts or perform any form of modification or repair on this product by yourself, so as not to affect your right to enjoy normal warranty services.

※ MEAN WELL reserves the right to revise the user manual. If there is any revision, please refer to the MEAN WELL official website for information . <https://www.meanwell.com>



8.Environmental declaration information

https://www.meanwell.com//Upload/PDF/RoHS_PFOS.pdf

https://www.meanwell.com//Upload/PDF/REACH_SVHC.pdf

https://www.meanwell.com//Upload/PDF/Declaration_RoHS-C.pdf

明緯企業股份有限公司
MEAN WELL ENTERPRISES CO., LTD.

248 新北市五股區五權三路28號
No.28, Wuquan 3rd Rd., Wugu Dist., New Taipei City 248, Taiwan
Tel:886-2-2299-6100 Fax:886-2-2299-6200
<http://www.meanwell.com> E-mail:info@meanwell.com